

It's All About
People.
And Technology.



KePlast i-series

The scalable automation solution
for injection molding machines

KEBA[®]
Automation by innovation.

It's All About People. And Technology.

In line with the credo, „Automation by innovation“, the international network of highly experienced employees develops cutting-edge solutions accustomed and optimized to the needs of the plastics and die casting industries.



Listening. And Understanding.

We speak the specialist language of the plastics industry thanks to our comprehensive understanding of the markets, processes, and technologies.



Partnership. And Choices.

Stronger together! Our belief is that the vital ingredient of long-lasting partnerships is high-level service and instant support – wherever and whenever you need it.



Performance. And Growth.

Combining your know-how with our expertise, we jointly develop innovative solutions that give you a competitive edge.



Why KePlast i-series from KEBA?

Due to constant improvements and innovations, KePlast is a state-of-the-art control system solution perfectly designed for injection molding machines.

So whether you need a cost-friendly turnkey, lightly customized, or utterly new solution, we are here to realize the vision.

Benefits at a glance

For the machine producer

- // Scalable range of powerful, compact, and modular controls & I/Os
- // Wide range of intuitive HMI panels
- // Future-proof & state-of-the-art Linux platform
- // Unique KePlast Application Framework for quick commissioning
- // Connection of machine fleet with OPC UA
- // One software for all injection molding machine types
- // Innovative closed-loop concepts

For the end user

- // High-quality, reliable hardware
- // HMI developed closely with the end-user for the best usability
- // Easy connectivity with OPC UA & EUROMAP
- // ServiceNet Remote support solution
- // EasyNet MES monitoring solution



Courageous visions need solid ground

Discover the unique KePlast i-series portfolio – the innovative, turnkey control platform for injection molding machines.

The KePlast control solutions cover a wide range of machine types, from standard hydraulic, through all-electric, to complex, multicomponent injection molding machines (IMMs).

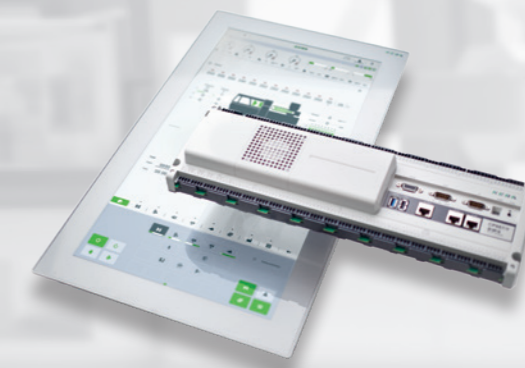

KePlast i1100 / i1100 Eco

The well-accepted keyboard operation and powerful control make the KePlast i1100 perfectly designed for standard hydraulic machines.

- // For standard hydraulic injection molding machines
- // 8" to 12" operator panels with keyboard operation
- // Up to 62.5µs fast cut-off reaction
- // OPC UA & EUROMAP interfaces
- // EtherCAT high-speed connectivity control



Datasheet
KePlast i1100



Datasheet
KePlast i1100 Eco

KePlast i2900

The hardware consists of a top-performance single-board control with a scalable performance level. The i2900 series comes with an analog resistive single-touch operator panel.

- // For hydraulic, hybrid & all-electric IMMs
- // 12" to 15" operator panel with singletouch screen
- // Seamless integration of KEBA drive technology incl. ready-to use packages
- // Linux software platform with OPC UA & EUROMAP interfaces



Datasheet KePlast i2900

KePlast i3000

With its high-performance control system and innovative & fast multitouch operating panels, KePlast i3000 stands out with an optimized combination fitting perfectly for high demands.

- // For hydraulic, hybrid, all-electric, and multi-component IMMs
- // 15" to 18" passive multitouch HMI panels with established key operation
- // Linux based & ready for any Industry 4.0 requirement incl. OPC UA & EUROMAP
- // New & innovative closed-loop concepts



Datasheet KePlast i3000

KePlast i8000

KePlast i8000 is the premium league player of the scalable i-series portfolio. The outstanding XL multitouch HMI screen allows intuitive controlling, taking the machine operation to a new dimension.

- // For hydraulic, hybrid, all-electric multicomponent machines as well as high tonnage IMMs
- // 21" active Linux based multitouch HMI panel
- // Perfect solution for large-scale machines and complex HMI requirements due to separated active panel
- // Panel distance up to 100m from control cabinet



Datasheet KePlast i8000

Flexible, modular & scalable hardware & software

Experience seamless symbiosis of software & hardware

In the technology world, a wholly original system consisting of software and hardware developed hand in hand for the highest compatibility always performs better than a system combining parts of various origins. KePlast portfolio provides numerous in-house developed, produced, and constantly enhanced software & hardware combination choices for any injection machine requirement.

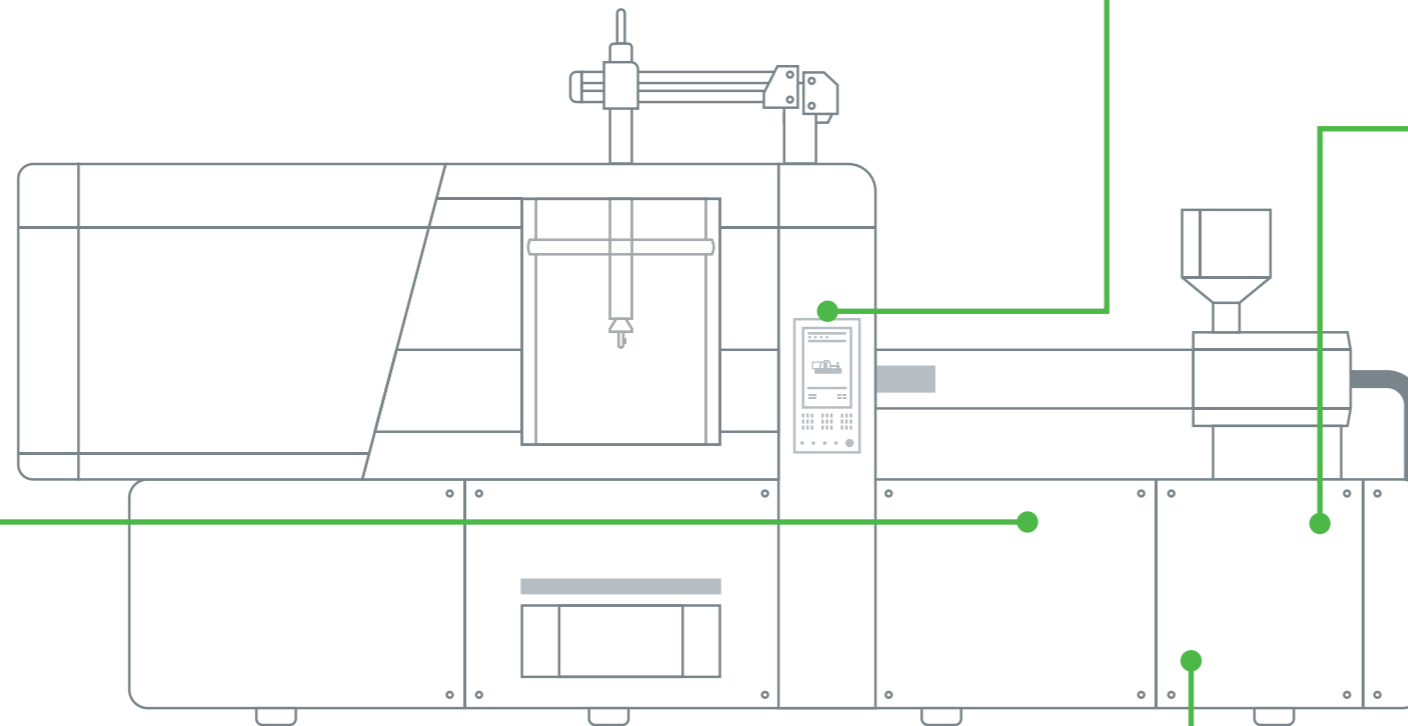

Controls

Powerful and scalable control platform

- // Intel x86 based CPU architecture – single to quad-core
- // Different performance classes for any application
- // CP 0xx line – compact control with integrated I/O board
- // CP 5xx line – modular configuration in combination with decentral I/Os
- // Linux-based & future-proof software architecture
- // Cycle time up to 500µsec



Human-machine interface (HMI) – Visualization

Modern, user-friendly, and powerful stationary and mobile operating panels for the best usability

- // **AP 500 (Active Panel)** 21" PCT multitouch screen for innovative and cutting-edge gesture operation based on Linux, including a top-performance multi-core CPU
- // **OP 500 (Passive Panel)** series with 15" and 18" high-end PCT multitouch screens via DVI interface, optionally with established machine keyboards and switches
- // **OP 300 (Passive Panel)** series with 8", 10", 12", and 15" brilliant TFT displays via DVI interface enable operation via microswitch keyboard or single-touch screen
- // **KeTop Mobile** series with 7" and 10" handheld devices for peripheral applications and robotic



Drives & motors

Exceptional drives and motors – designed for maximal performance while keeping energy costs at a minimum

- // Optimized package for all-electric and hybrid machines
- // Wide power range of up to 630A peak current
- // Single-, double-, and triple-axis modules
- // EtherCAT high-speed communication
- // Condition monitoring feature to realize predictive maintenance solutions and increase the productivity



I/O modules & technology extensions

A wide range of high-end I/O modules – connectable directly to the control or via bus coupling

- // Digital or analog inputs and outputs
- // Temperature inputs with galvanic isolation
- // Special modules and bus interfaces
- // High-speed EtherCAT fieldbus enables top control quality
- // Ultra-compact I/O pin size of 3.81mm



Optimized packages: For all-electric & hybrid machines

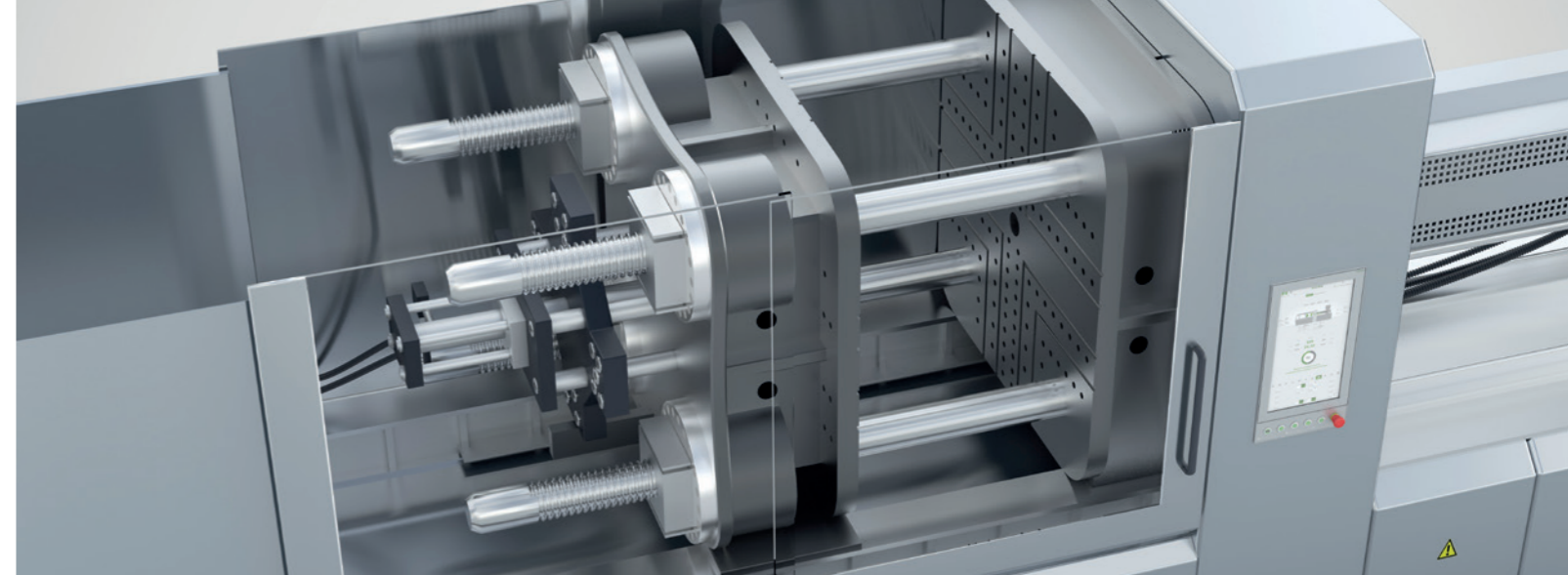

High-performance drive technology

A comprehensive range of drives and motors is available for all electric and hybrid injection molding machines. They are cost-optimized and offer a high degree of flexibility with regard to the design of the machine configurations. Whether highly dynamic applications with low power requirements or high-energy installations with an injection power of up to 120 kW and 630A peak current. The supply units are optionally available with regenerative power feedback, which enables a reduction of power costs.

Control at the highest level

Intelligent pressure closed loop on drive feature guarantees extremely short response times and optimal process behavior. The possibility of coupling drives and, by doing so, further increasing performance and dynamics offers unique flexibility. Whether rigidly coupled systems or master & slave drive combinations with intelligent software, the right solution is available for every machining requirement.

Prolong lifetime & avoid downtime

Use drive-based condition monitoring to realize predictive maintenance solutions and increase the productivity of your machine in terms of long-lasting performance without downtimes. The drive unit internally collects relevant data, converts it, and compresses it based on intelligent mathematical models.

Focus on energy efficiency

In factory automation, the drive systems account for one of the largest share of the energy consumed. Active energy recovery systems limit expensive energy peak loads. Optional capacitor modules store energy temporarily, intelligent energy storage systems protect against power outages.



For high-end hydraulic machines

Ready-to-use solution for two-platen machines

With products ranging from the i2000 to the i8000 series, KePlast offers a complete package for two-platen machines. Due to the comprehensive KePlast Application Framework and a comfortable integration in the engineering tool suite, these injection molding machines can be easily realized.

Furthermore, with our ready-to-use KePlast systems, you can even equip the large-tonnage machines with complex processes and additional peripheral devices. This leads to fast commissioning and a short time to market for your competitive advantage.

Comprehensive technology functions

Due to the KePlast closed-loop control, a smooth, fast, and accurate movement of the mold is guaranteed, which is achieved by perfect lock-nut synchronization. In combination with an optimized control of the core sequences, you can reach the highest process quality as well as the shortest cycle time.

Following our credo of the easy-to-use approach, the programming of the molds and core movements can be done easily with the KePlast MachineSequencer. Without any further programming knowledge, even the most complex sequences, including parallel and special core movements, can be realized in a short amount of time.



KePlast software makes the difference

The unique KePlast concept results in a versatile software framework and smart engineering workflows. Our modular, open, and powerful KePlast software can be either used as a ready-to-use solution or as an ideal starting point for further development up to customer-specific adaptations. With KePlast, you can realize a fast time-to-market and gain a competitive advantage.

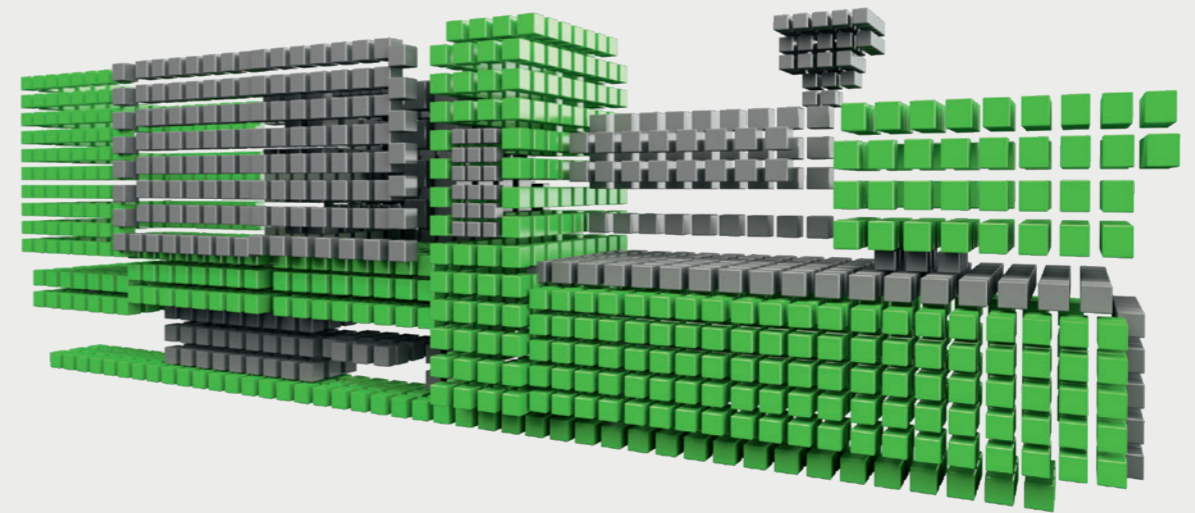

+

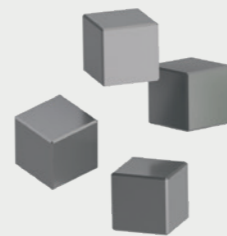

+

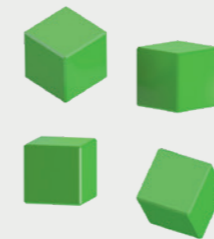

=



Plastics technology libraries

- // Temperature control
- // Closed loop control
- // OPC UA & EUROMAP interfaces
- // Energy-saving modules

Helpful wizards for the process excellence

- // Software assistants
- // Integrated diagnostics
- // Machine sequencer
- // Machine and movement ramp calibration

Optimized engineering workflows

- // Application composer
- // Continuous integration
- // Product line management for mass production
- // Simulation & Digital Twin

Commissioning in 3 days

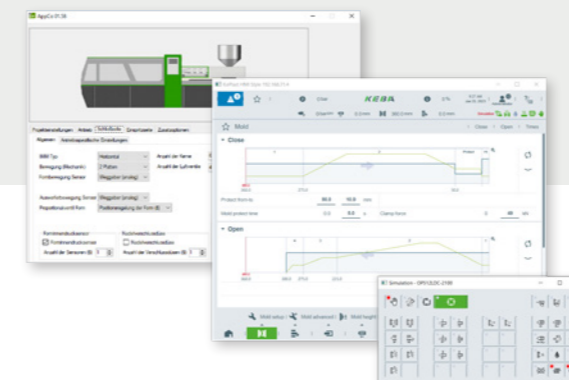
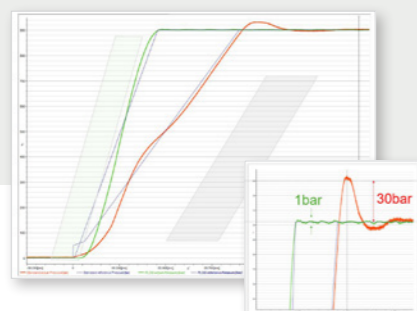

Interested in our software?
Check out our website for detailed
software features descriptions.



KePlast Smart Industry

Mastering digital transformation together.

With the increasing need for flexibility and individualization, production processes are becoming more and more complex. KEBA provides innovative automation solutions for Industry 4.0 for the digitization of machines and production.

KePlast Smart Factory

Assistance programs for increased productivity at the end-customers' factory

KePlast EasyNet 4 Professional manufacturing execution system (MES) monitors machine productivity and manages its data on stationary and mobile end devices for small and medium-sized companies. In addition, KePlast ServiceNet enables worldwide access to machines and rapid problem-solving by experts and guarantees the fastest communication due to a global IT infrastructure.

KePlast Smart Technology

Future-proof technology libraries and wizards for the machine

The complete technology libraries allow high-quality processes for sophisticated applications. These modules enable numerous communication protocols and standards, such as OPC UA and EUROMAP. Several smart wizards, such as KePlast MachineSequencer, support the process operator in daily business.

KePlast Smart Engineering

User-friendly engineering and tools for the OEM's fast machine configurations

With the ergonomic tool KePlast AppCo, the OEM customers can easily configure the machine software without extensive training – this is also applicable for high-volume customers with many machine variations while implementing overall product line management workflows.

KePlast
Smart
Industry

EasyNet 4 Professional - process monitoring for maximum productivity

As part of KEBA's digitalization portfolio, EasyNet is a user-friendly program that enables the reliable networking of injection molding machines at a high price-performance ratio. In addition, it is ideal for central data acquisition and backup. With EasyNet, you have an overview of your production machines at all times – while the short reaction time ensures the highest performance.



Brochure KePlast EasyNet

ServiceNet remote access – in seconds on your machine

KePlast ServiceNet is a user-friendly plug & play solution for secure comprehensive remote support and efficient distant monitoring. Fast, worldwide access to process data for service as well as convenient remote diagnosis are as simple and uncomplicated as the support of the operative staff in application and process queries.

Tailormade technologies & workflows for plastics machines

The Kemro X platform is the basis of all our solutions. In all phases of the automation cycle, our KePlast software provides the perfect support: From innovative software technologies, through engineering and commissioning, to the machine operation and production tools.

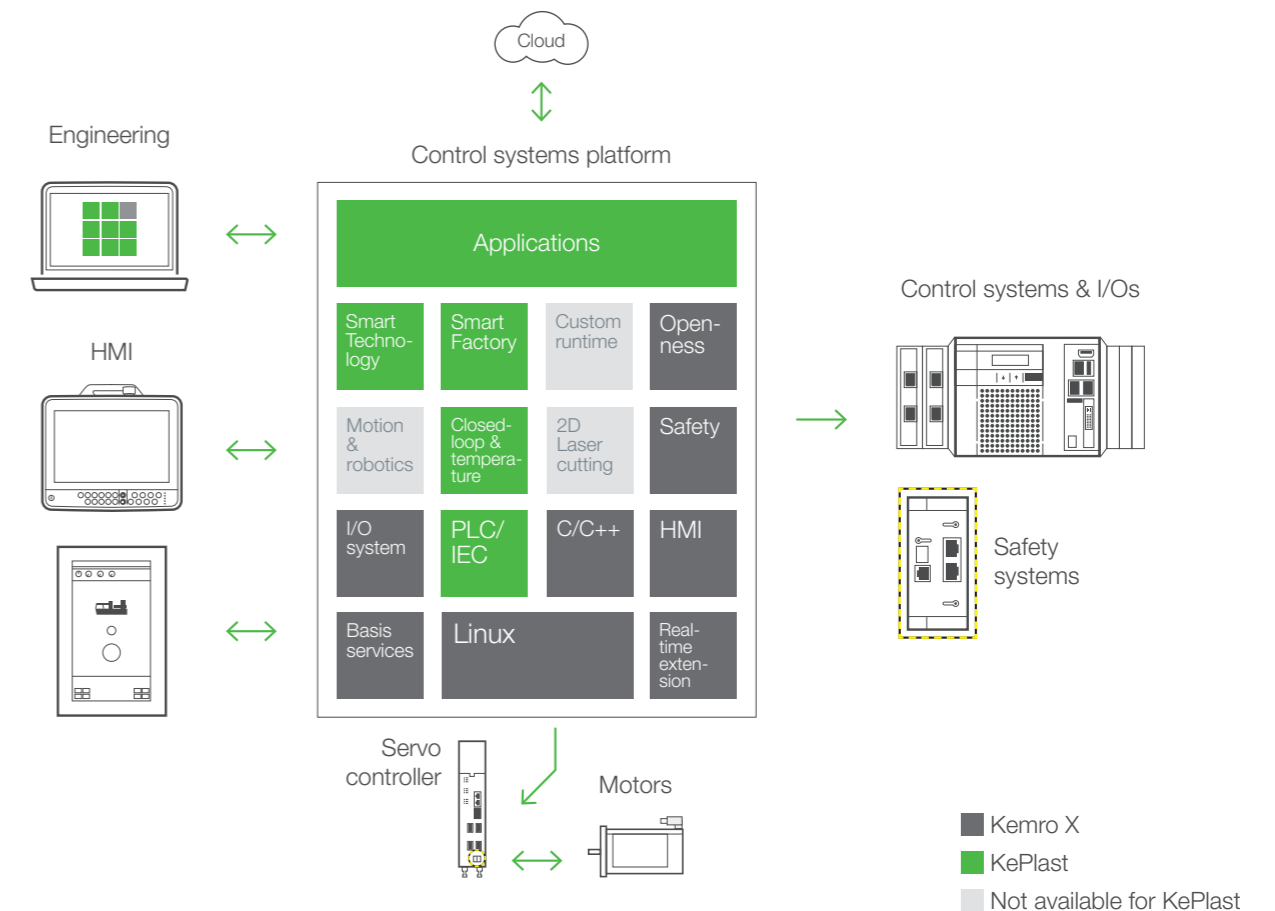

KEBA Industrial Automation GmbH

Reindlstraße 51, 4040 Linz/Austria, Phone +43 732 7090-0, keba@keba.com

KEBA Group worldwide

Austria / China / Czech Republic / Germany / India / Italy / Japan / Netherlands

Romania / Serbia / South Korea / Switzerland / Taiwan / Turkey / United Kingdom / USA

www.keba.com

